

## XYZ 2010 HD

Spindle: 10,000 rpm  
Table Size: 2,200 x 1,000mm  
Travels: 2,000 x 1,000 x 800mm  
Machine Weight: 20,000kg

## XYZ 2510 HD

Spindle: 10,000 rpm  
Table Size: 2,700 x 1,000mm  
Travels: 2,500 x 1,000 x 800mm  
Machine Weight: 23,000kg

## XYZ 3010 HD

Spindle: 10,000 rpm  
Table Size: 3,100 x 1,000mm  
Travels: 3,000 x 1,000 x 800mm  
Machine Weight: 25,000kg

**SIEMENS**  
Touchscreen

**HEIDENHAIN**  
Touchscreen

**1 metre  
Y axis**

**HARDENED BOX  
SLIDEWAYS**

**HD**  
HEAVY DUTY



## The XYZ Super Heavyweights with up to 3 metres of travel.

As British manufacturing grows, so it seems do the size of the components it needs to machine, with oil, gas, aerospace and renewables demanding larger capacity machine tools. Enter the XYZ Super Heavyweight VMCs, with up to 3,000mm x 1,000mm x 800mm of travel.

Backing up this capacity is the 25 tonnes of solid Meehanite casting, with wide box slideways, six on the Y axis alone.

### Six hardened box way slides

*The XYZ Heavyweights have 6x 'hardened box way' slides on the Y axis for assured accuracy across 1,000mm.*

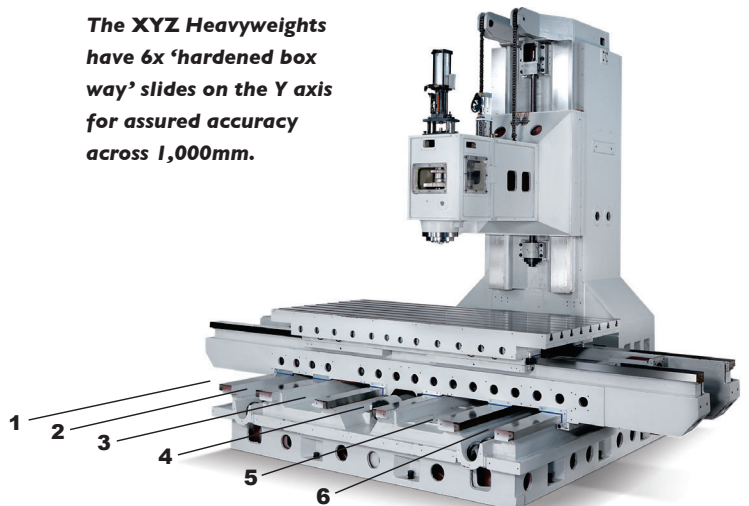

**XYZ 2010 HD**

**XYZ 2510 HD**

**XYZ 3010 HD**

### Standard Equipment

- Siemens 828D ShopMill Control.
- Coolant System.
- Auto Lubrication System.
- Work Lamp.
- Remote Electronic Handwheel.
- Spindle Air Blast.
- Auto Power Off (M30).
- BT40 Spindle (BT50 optional).
- Heat Exchanger for Electrical Cabinet.
- Rigid Tapping.
- Spindle Oil Cooler.
- Chip Conveyor with Bin.
- Pull Studs.
- Networking.
- USB Port.
- Compact Flash Card Slot.

### Optional Equipment

- Through Spindle Coolant.
- Upgrade to BT50.
- Geared Head.
- 4th Axis Rotary Table.
- 5th Axis Rotary Table.
- Offline Programming.
- Renishaw/Heidenhain Toolsetting and Probing.
- Contour Handwheel (*wind the handwheel to run through the program*).
- Advanced Swarf Management System.
- Coolant Washdown Gun.

Specification	XYZ 2010, 2510, 3010 HD
X Axis Table Travel	2,000 / 2,500 / 3,000mm
Y Axis Table Travel	1,000mm
Z Vertical Travel	800mm
Spindle to Table	185 - 885mm / 185 - 985mm
Table Size	2,200 / 2,700 / 3,100 x 1,000mm
Column Front to Table Centre	600 - 1,600mm
Rapid Feedrate	16 M/min
Cutting Feedrates	1-16,000 MM/min
Ballscrew (Grade C3)	50mm Dia P12
T Slot Size	22mm
T Slot Number & Pitch	8 off @ 125mm Pitch
Slideway Type	Hardened Boxway (6 Slides on Y Axis)
Max Table Load	3,000 / 3,200 / 4,000kg
Toolchanger	30 Station Carousel
Max Tool Diameter (BT40)	77mm
Max Tool Weight (BT40)	7kg
Spindle Speeds	5 - 10,000 rpm (Options Available)
Spindle Motor	23kW (30hp) continuous, 27kW (36hp) 30 minutes, 42kW (56hp) 2.5 minutes in 10
Coolant Tank Capacity	700L / 700L / 1,000L
Machine Weight	20,000 / 23,000 / 25,000kg

Conforming to ISO 10791	
Positional accuracy	+/- 5 microns
Repeatability	+/- 2 microns
Circularity over 300mm	6 microns
Geometric accuracy over 300mm	6 microns

### With Linear Roller Bearing Slides

A larger bearing contact area for high speed precision and enhanced stiffness and rigidity.

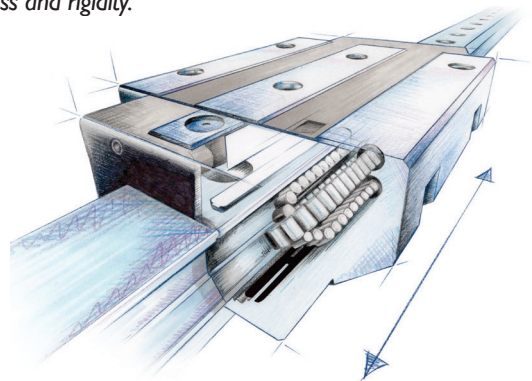

Part of the **XYZ Catalogue 2024/25** which includes:  
**ProtoTRAK® Turret Mills.**  
**ProtoTRAK® Bed Mills.**  
**ProtoTRAK® TMCs.**  
**Vertical Machining Centres.**  
**5 Axis Simultaneous VMCs.**  
**Manual Mills & Lathes.**  
**Grinders.**  
**Tooling & Accessories.**



Visit [www.xyzmachinetools.com](http://www.xyzmachinetools.com) or our YouTube channel to see the video.